

NO.	TASE-5030	DESCRIPTION
1	EG-9479	ASSEMBLY
2	CT-9725	AFTERCoolER TUBE
3	357-9401	FILTER ASSEMBLY
	357-9701	AIR FILTER
4	UNL-9708	THROTTLE CONTROL ASSY.
5	GA-250	GUAGE 300 PSI.
6	TIA-5200	SAFETY VALVE 200 PSI.
7	SS-2707	DRAIN COCK
8	VAGE-9402	13 HP. HONDA GAS ENGINE
9	TA-9418-4	TANK 30 GAL.
10	UNL-9707	CHECK VALVE & UNLOADER
11	VA-9705	BALL VALVE
12	BT-9031	(2) BX79 BELTS
13	PU-9712	PULLEY
14	247-4523	COMPRESSOR PUMP

REV.	DATE	REVISION DESCRIPTION	PCN NO.
	15APR98	NEW	98-11

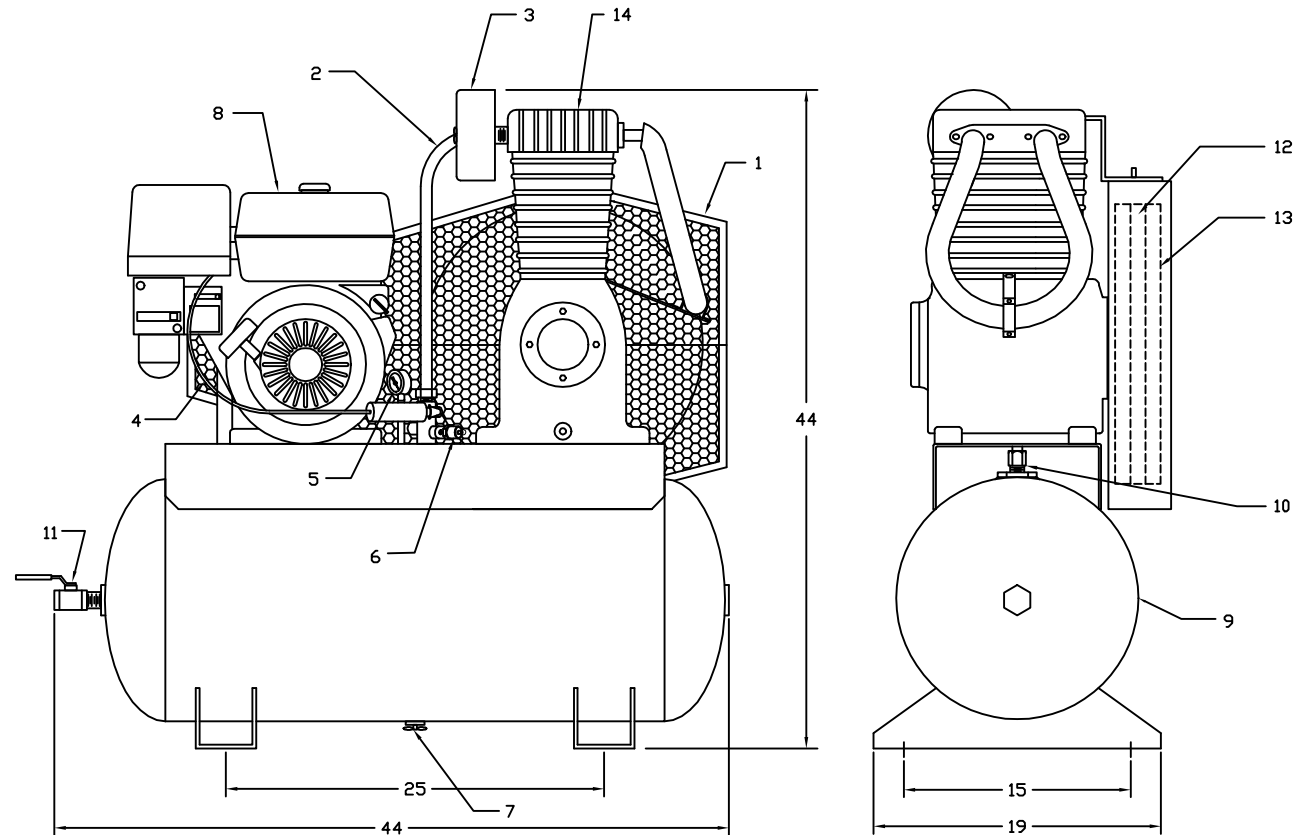

IMPORTANT NOTE: This print is the confidential property of DEVAIR, INC. It is not to be used or reproduced in any manner, nor submitted to other parties for examination without the prior approval of DEVAIR, INC.

FRACTIONAL DIMENSIONS:  $\pm 1/32$   
 DECIMAL DIMENSION:  $\pm .005$   
 ANGLES:  $\pm 1'$   
 \*UNLESS OTHERWISE SPECIFIED

**DEVAIR**

NAME OF PROJECT		DESCRIPTION OF DRAWING	
13 .HP., 30 GAL., 175 PSI PRESSURE		GAS DRIVEN AIR COMPRESSOR	
DRAWN BY: IRAJ FILSOOFI		CHECKED BY:	DATE: 28 APR/00
		SCALE: N.T.S.	
		DRAWING NO. TASE-5030	SHT NO/REV