

NO	TAS-5052-MS	DESCRIPTION
1	247-4502-P	COMPRESSOR PUMP
2	EG-9485	GUARD ASSEMBLY
3	MD-9033	7.5 HP. MOTOR 230/1
	MD-6507	7.5 HP. MOTOR 200/3
	MD-6535	7.5 HP. MOTOR 230,460/3
	MD-6514	7.5 HP. MOTOR 575/3
4	SSS-9003U115150	PRESSURE SWITCH
5	GA-250	GAUGE, 300 PSI. 2" DIA.
6	TA-9497-1	TANK 80 GAL.
7	TIA-5200	SAFETY VALVE, 200 PSI.
8	VA-9705	BALL VALVE
9	SS-2707	DRAIN COCK
10	357-9401	FILTER ASSEMBLY
	357-9701	AIR FILTER
11	CT-9726	AFTERCOOLER TUBE
12	CT-9728	PRES. RELEASE TUBE
13	MS-140-03	MAG STARTER 230/1
	MS-340-41	MAG STARTER 200/3
	MS-340-43	MAG STARTER 230/3
	MS-340-45	MAG STARTER 460/3
	MS-340-69	MAG STARTER 575/3
14	MH-9001	WIRING HARNESS, 1 PHASE
	MH-9004	WIRING HARNES, 3 PHASE
15	CCV-9403	CHECK VALVE
16	BT-39	(2) B81 BELTS
17	PU-9196	PULLEY

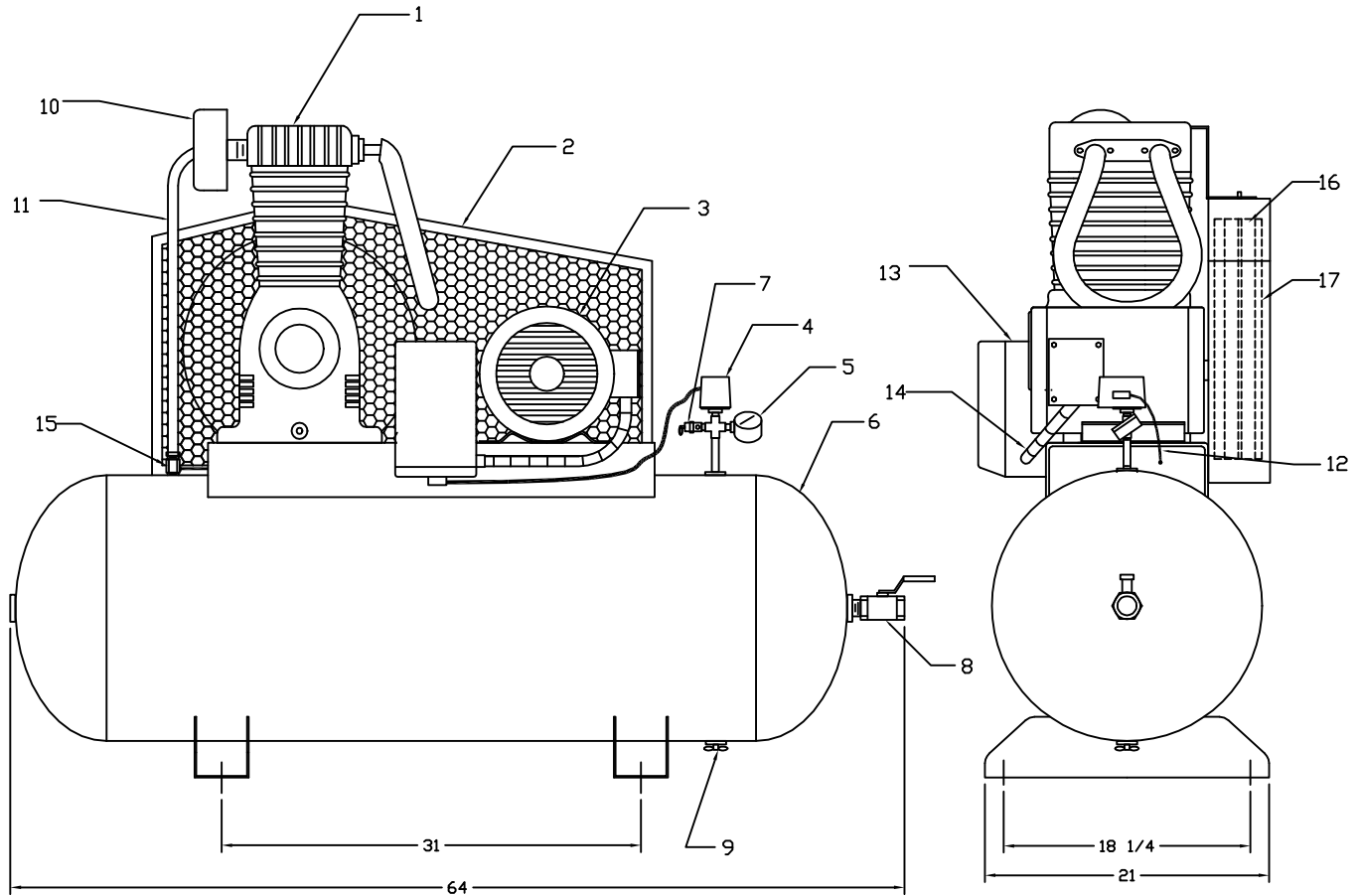

REV.	DATE	REVISION DESCRIPTION	PCN NO.

IMPORTANT NOTE: This print is the confidential property of DEVAIR, INC. It is not to be used or reproduced in any manner, nor submitted to other parties for examination without the prior approval of DEVAIR, INC.

FRACTIONAL DIMENSIONS: $\pm 1/32$
 DECIMAL DIMENSION: $\pm .005$
 ANGLES: $\pm 1'$
 *UNLESS OTHERWISE SPECIFIED

DEVAIR

NAME OF PROJECT		DESCRIPTION	
7.5 HP., 80 GAL., 175 PSI PRESSURE		COMPRESSOR OUTFIT	
DRAWN BY	CHECKED BY	DATE	SCALE
IRAJ FILSOOFI		28 APR/00	N.T.S.
DRAWING NO.		SHT NO/REV	
TAS-5052			